

# WORLD MARKET®

## Assembly Instructions

Avila Extension Dining Table

SKU-602534



THANK YOU FOR PURCHASE. IF YOU HAVE ANY QUESTIONS  
PERTAINING TO THE ASSEMBLY OF THIS FURNITURE PIECE, PLEASE CONTACT  
THE NEAREST WORLD MARKET STORE.  
IF YOU ARE NOT NEAR A STORE, PLEASE CALL OUR CUSTOMER SERVICE CALL  
CENTER TOLL FREE AT 877-967-5362 FOR ASSISTANCE.

All products sold at World Market  
are not for commercial use and are  
intended for residential use only.

# Component List

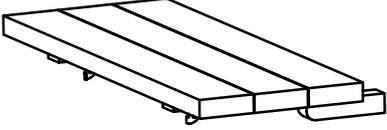
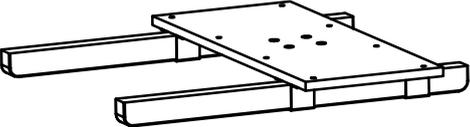
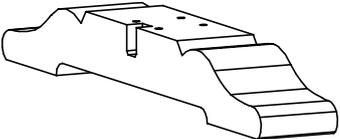
LABEL	PICTURE		
A		Table Top	1
B		Extension Table Top	2
C		Table Support Panel	2
D		Leg Post	2
E		Stretcher	1
F		Leg Base	2

# Hardware List

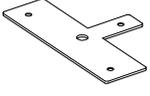
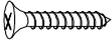
LABEL	PICTURE	DESCRIPTION	
H-1		Spring Washer Ø13 x M8	
H-2		Flat Washer Ø17 x M8	32
H-3		Connector Plate	2
H-4		Screw M6 x 3/4 Inch	6
H-5		Extra Short Allen Bolt M6 x 35mm	8
H-6		Short Allen Bolt M6 x 40mm	16
H-7		Medium Allen Bolt M6 x 70mm	2
H-8		Long Allen Bolt M6 x 100mm	8

# Tool List

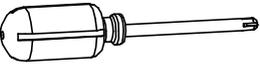
LABEL	PICTURE	DESCRIPTION	QTY
T-1		Allen Key	1
T-2		Phillips Screw driver ( Not Included )	1

# Assembly Preparation

Before Beginning :

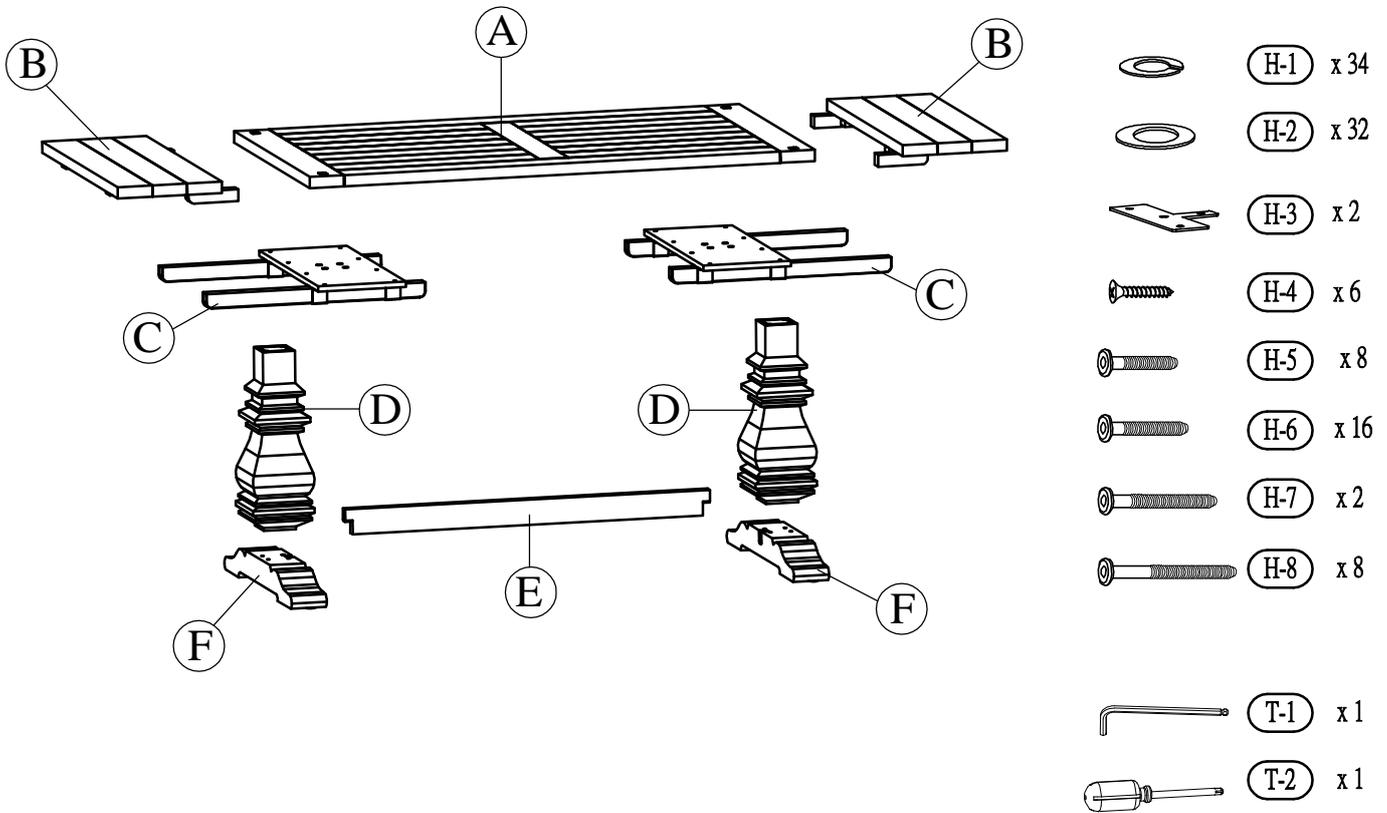

- Unpack all hardware bags and components to ensure you have all parts-



- Read instructions, cover to cover-



- Have 2 adults on hand for assembly-



- Do not assemble on flooring or carpet-



- Assemble on a clean non-marring surface (packing foam)-



- Save all packaging until finished-



- In case of missing parts, please contact your nearest World Market store or call our customer service call center at call 1-877-967-5362.

# Assembly Steps

## STEP 1 : Attaching Foot Leg

-  (H-1) Spring Washer (φ13xM8) x 8
-  (H-2) Flat Washer (φ17x M8) x 8
-  (H-8) Long Allen Bolt (M6 x 100) x 8

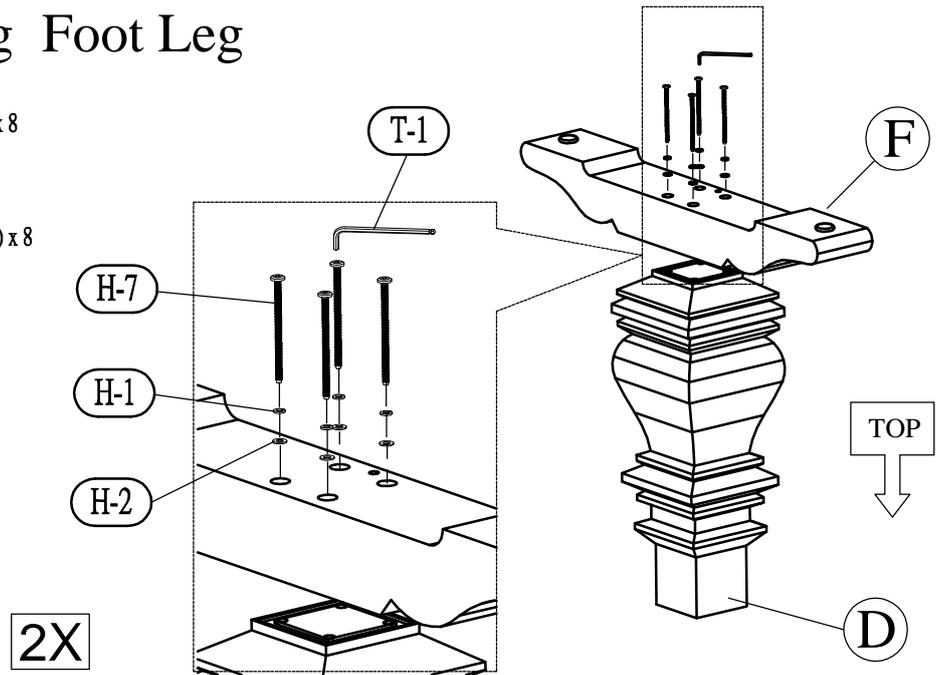

Attach Leg Base (F) to Leg Post (D) using Long Allen Bolts (H-8), Spring Washer (H-1) and Flat Washer (H-2), Stacking the hardware in the order as shown . Engage all bolts by hand first, then fully tighten using Allen Key (T-1). Repeat this step for the second Leg (D/F) assembly.

## STEP 2 : Attaching Stretcher

-  (H-1) Spring Washer (φ13xM8) x 2
-  (H-7) Medium Allen Bolt (M6x70) x 2
-  (H-3) Connector Plate x 2
-  (H-4) Screws (φ6 x 3/4 Inch) x 6

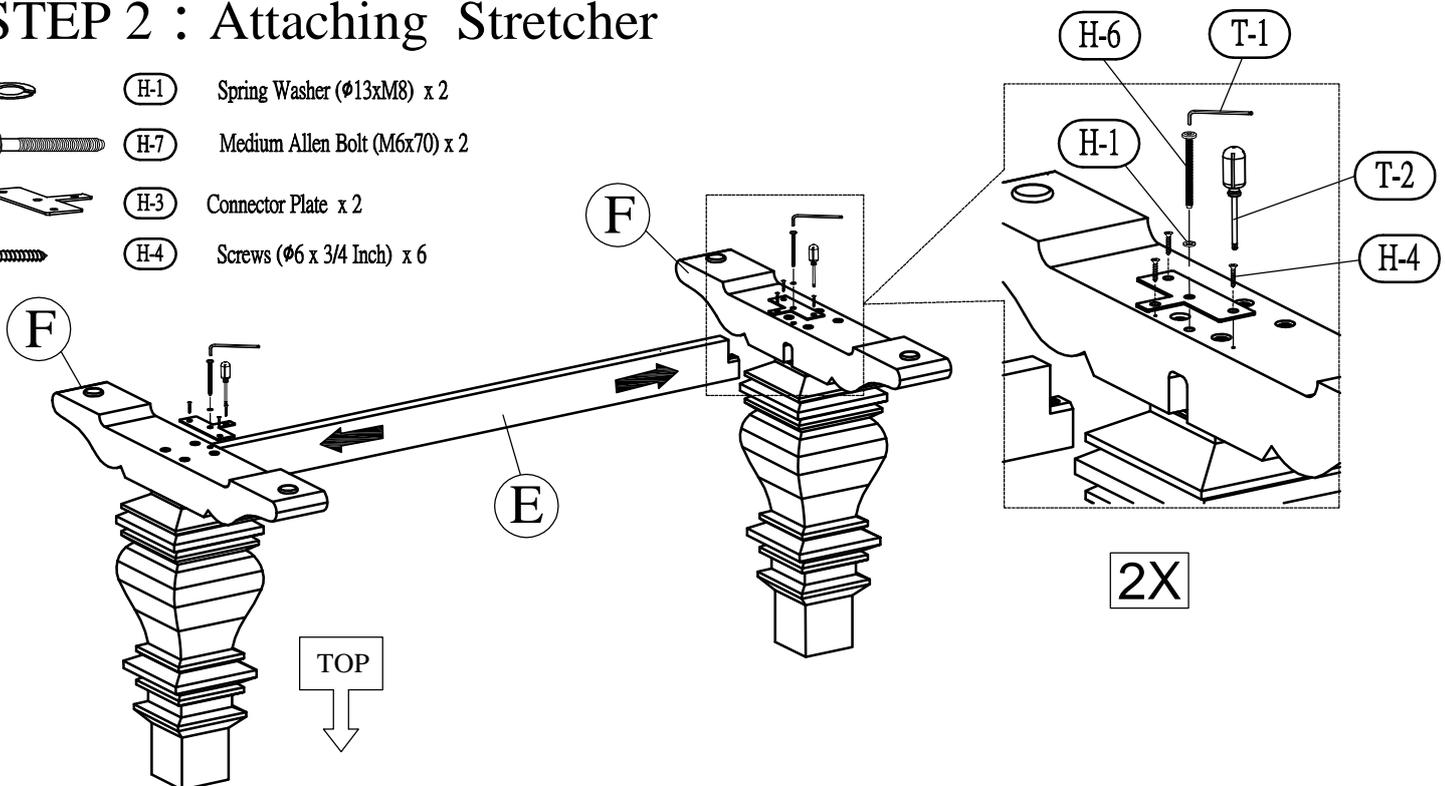

Using a second person to assist you, insert Stretcher (E) into the corresponding notched hole at each Leg Base (F) assembly as shown. Align Connector Plate (H-3) with the corresponding pre-drilled holes on the bottom of each Leg Base (F) as shown. Start by securing the middle hole of the Connector Plate (H-3) which will also secure the Stretcher (E) using Medium Allen Bolts (H-7) and Spring Washers (H-1). Engage the bolts by hand, but do not fully tighten them yet. Next, finish securing Connector Plate (H-3) using Screws (H-4) and a Phillips head screwdriver (not included). Fully tighten all bolts and screws at this time using Allen Key (T-1) and a Phillips head screwdriver.

# Assembly Steps

## STEP 3 : Attaching Support

-  (H-1) Spring Washer (Ø13xM8) x 8
-  (H-2) Flat Washer (Ø17x M8) x 8
-  (H-5) Extra Short Allen Bolt (M6 x 35) x 8

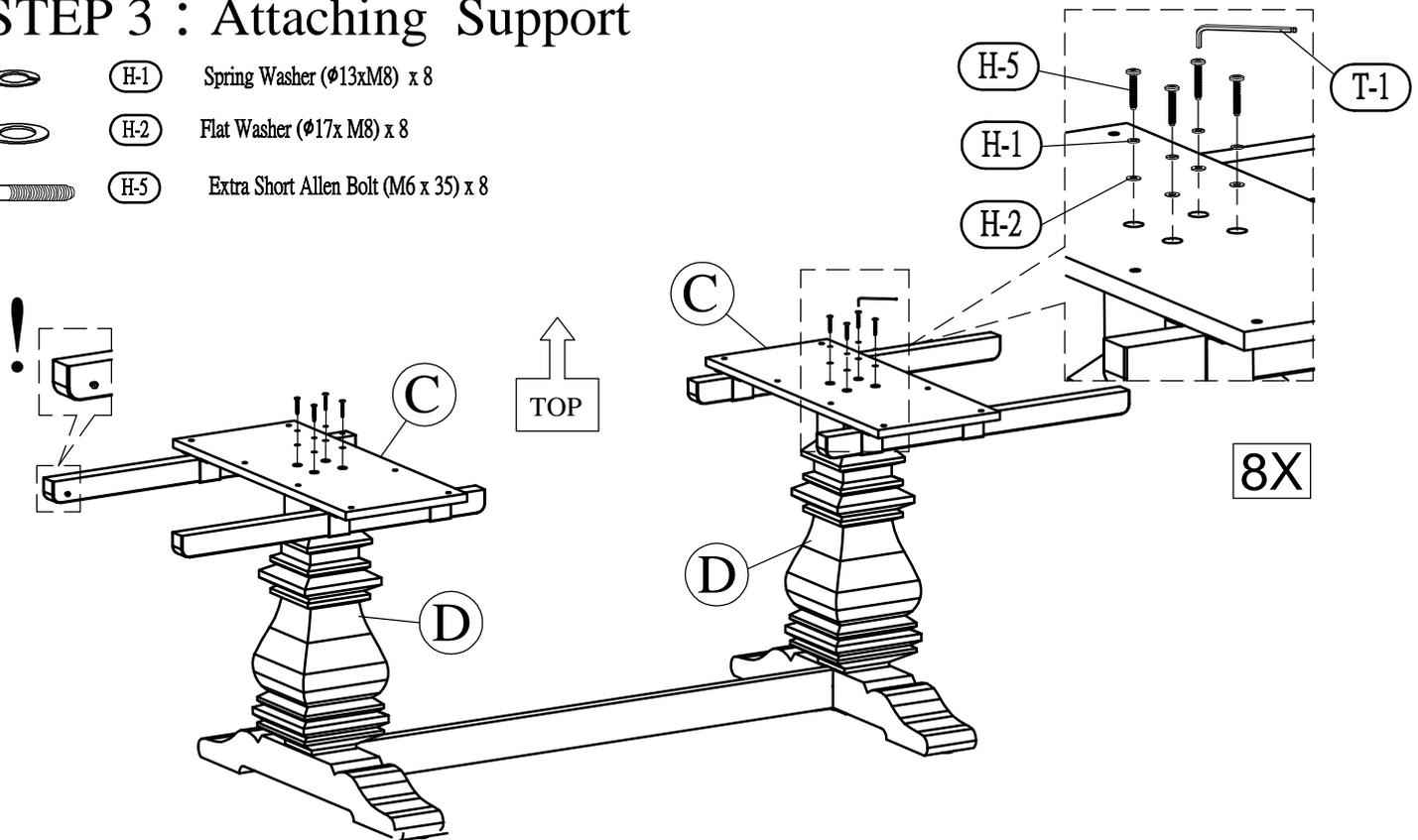

Using a second person to assist you, carefully turn the assembly from Step 2 upright as shown. Align Table Support Panels (C) with the corresponding pre-drilled holes on the tops of the Leg Posts (D) as shown. Note the orientation of the support rails, they should face outwards as illustrated. Secure the Table Support Panels (C) using Extra Short Allen Bolts (H-5), Spring Washers (H-1) and Flat washers (H-2), stacking the hardware in the order as shown. Engage all bolts then fully tighten them using Allen Key (T-1).

## STEP 4 : Assembling Top

-  (H-1) Spring Washer (Ø13xM8) x 16
-  (H-2) Flat Washer (Ø17x M8) x 16
-  (H-6) Short Allen Bolt (M6 x 40) x 16

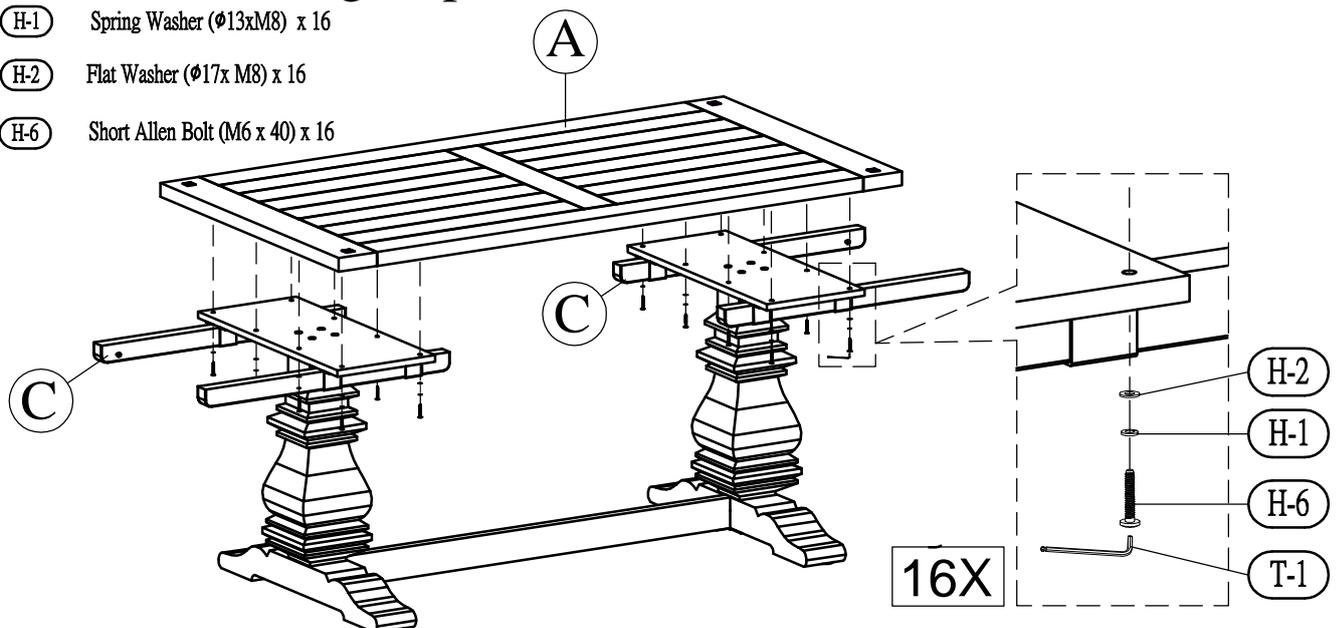

Using a second person to assist you, carefully lower Table Top (A) down into position onto Table Support Panels (C) as shown. Secure Table Top (A) using Short Allen Bolt (H-6), Spring Washer (H-1) and Flat Washers (H-2), stacking the hardware in the order shown. Engage all bolts by hand first, then fully tighten them using Allen Key (T-1)

# Assembly Steps

## STEP 5 : Attaching Extension Table Top

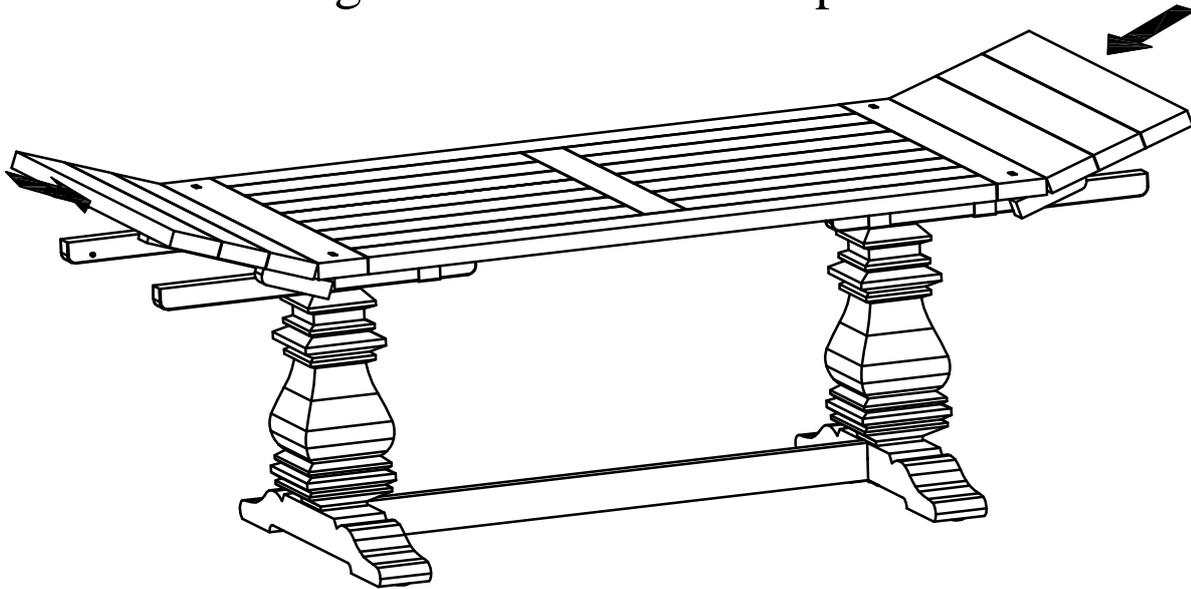

Insert both Extension Table Tops (B) into position as shown, making sure the lower wooden support arms hook under the main Table Top (A) assembly.

## STEP 6 : Lock Extension Table Top

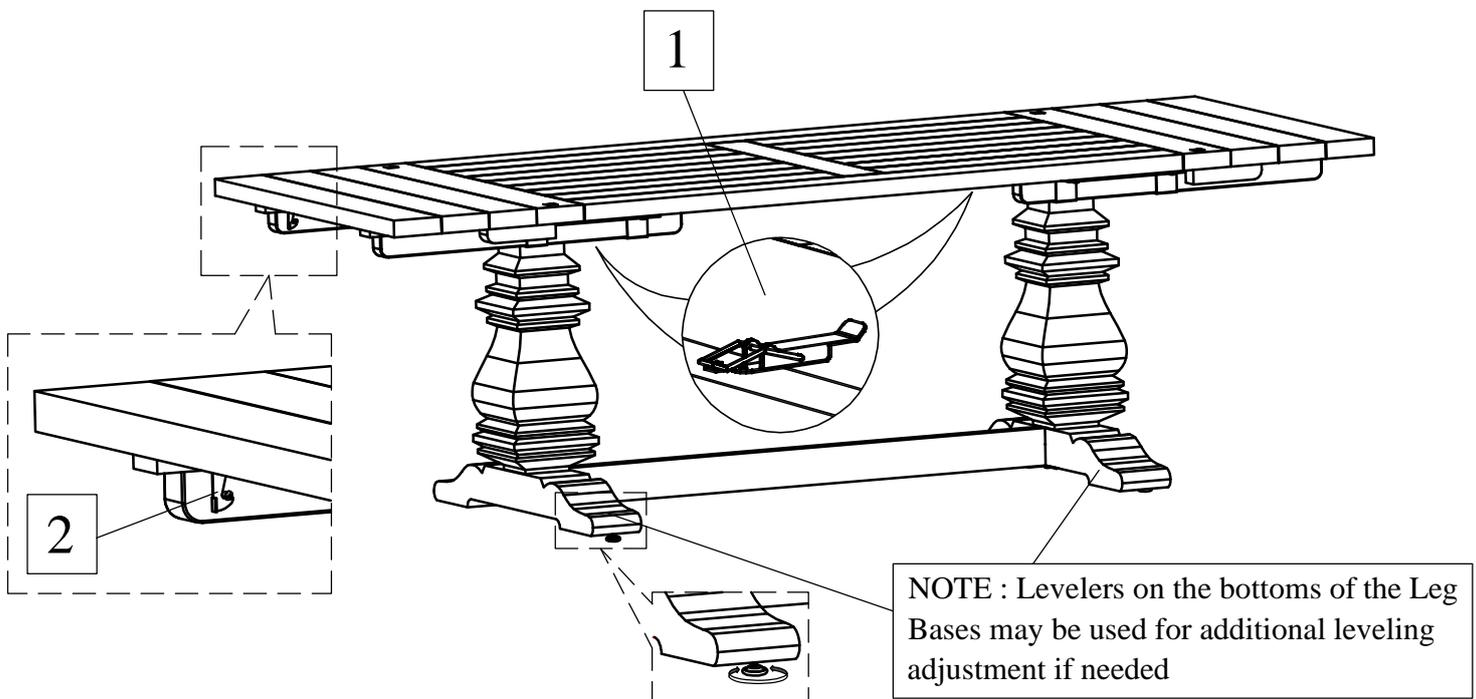

- 1) Ensure that the clasp ring on each toggle clamp has engaged the corresponding hook and then push the clamp closed
- 2) Next, make sure the hook has engaged the pin on the inner edges of both Table Support Panels.

Ensure that all bolts have been fully tightened at this time. Assembly is now complete and product is ready for use

# Care & Maintenance

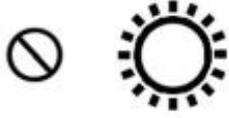
-  • Do not put hot items directly on furniture surface.
  -  • Do not clean furniture with harsh cleansers or polish.
  -  • Do not place furniture in direct sunlight.
  -  • Do not place furniture near heating or cooling vents.
  -  • Do not write on furniture without a padded barrier to protect the surface.
  -  • Do not place furniture outside. For indoor use only.
  -  • All products sold at World Market are not for commercial use and are intended for residential use only.
- 
-  • Dust and pick-up spills using a clean, non-colored, lint-free, dry cloth.

# **WORLD MARKET LIMITED ONE-YEAR WARRANTY – Indoor Furniture**

For your customer satisfaction, this product carries a LIMITED ONE-YEAR WARRANTY from the date of purchase. This limited warranty only applies to World Market brand furniture, and not to other furniture brands sold on World Market's website.

Where applicable, the limited warranty provides coverage for:

1. **Manufacturing, Material and Workmanship Defects:** Includes defects related to core frame/structure substrates (wood and metal); cracking, splitting, or complete breakage of hardwood, plywood or medium density fiberboard (MDF); cracking, splitting or lifting of wood veneer or laminated top surfaces caused by process failure; broken welds or improperly coated metal frame components (powder coating or painted); fabric or leather material defects including tears, misprints, fraying, crease marks, skip stitches or open seams; support webbing material and sinuous spring defects or damage, including method of attachment to frame; and other component failures that are a direct result of manufacturing or workmanship defects.
2. **Cushions & Cushions with Enclosed Steel Pocket Coils:** Failed or ruptured steel pocket coils enclosed inside of seat cushions, or loss of resiliency from a material breakdown of foam or fiber filling, which should not be confused with softening or settling during normal use.
3. **Leather:** Splitting or cracking of leather material. NOTE: The warranty does NOT cover natural hide markings, variations in the leather color or grain due to the authentic natural properties of processed cowhide leather.
4. **Bonded Leather or Bi-cast Leather:** Separation of the polyurethane coating, peeling or cracking of the inner layer or at the bonded seam edges (bi-cast straps).
5. **Furniture Components (Hardware & Mechanisms):** Includes defects to pre-installed components or hardware provided to the customer for assembly such as office chair hydraulic lifts, lift mechanisms, metal bases and casters, swivel plate mechanisms; for drawers, metal glides, handles/knobs; for doors, hinges, magnetic latches; and other components such as bent or stripped threaded leg posts and adjustable levelers. For missing, damaged, corroded, or misplaced hardware components such as bolts or washers, please contact Customer Service at: 877-967-5362.

## **This LIMITED ONE-YEAR WARRANTY does NOT cover:**

1. Damage due to mishandling during transportation from store or transportation without original protective packaging.
2. Abuse, negligence (product misuse) or wear and tear that may result in or from:
  - a. **Wood & Veneer:** Mishandling, exposure to moisture, peeling or discoloration caused by exposure to moisture or excessive sunlight, heat; splintered, dented or nicked panels, legs or component edges or paint/finish blemishes; or treatment with corrosive chemicals (dyes, inks, paints or harsh cleaning products).
  - b. **Fabric & Leather (Including Bonded or Bi-Cast Leathers):** cuts, punctures, tears, burns, pet damage, or treatment with corrosive chemicals (dyes, inks, paints or harsh cleaning products), exposure to direct sunlight, fire, high heat, water, or any bright light source (natural or artificial) that may cause splitting, peeling or flaking with time.
  - c. **Foam (Cushions):** Flattening, relaxing or settling/softening of foam components that comes with normal use.
  - d. **Hardware Components:** improper installation or misuse/substitution of hardware components not defined in the Assembly Instructions for the product (if applicable)
3. Damage due to environmental exposure to direct sunlight, fire, high heat, water or extreme humidity, any bright light source (natural or artificial), or any environment that the product is not intended for.
4. This warranty is applicable for indoor furniture products purchased for residential use only.

For additional information on returns, please visit: <https://www.worldmarket.com/category/customer-service/returns.do>

**All products sold at World Market are NOT FOR COMMERCIAL USE and are intended for residential use only. Products purchased for commercial use will VOID all warranty provisions as listed above.**

Any claims under this LIMITED ONE-YEAR WARRANTY are valid and applicable only as to the original purchaser and must be accompanied by proof of purchase. Warranty claims should be submitted to a World Market store or through World Market Customer Service Call Center, Toll Free at 877-967-5362.

For valid warranty claims, World Market will repair or replace the product, or offer a full or partial credit, in the sole discretion of World Market. This LIMITED ONE-YEAR WARRANTY gives you specific legal rights and you may also have other rights which vary from state to state.